

DC Motor TW-550SP Series

OUTPUT POWER: 5.0 - 120W (APPROX)



Features:

* Carbon Brush Motor.

Weight:

215g (APPROX)

Typical Application:

1. Printer, Computer Peripherals, Drill, Screwdriver, Lumber Support, etc.
2. Car Antenna, Air Compressor, Coreless Garden Tools.

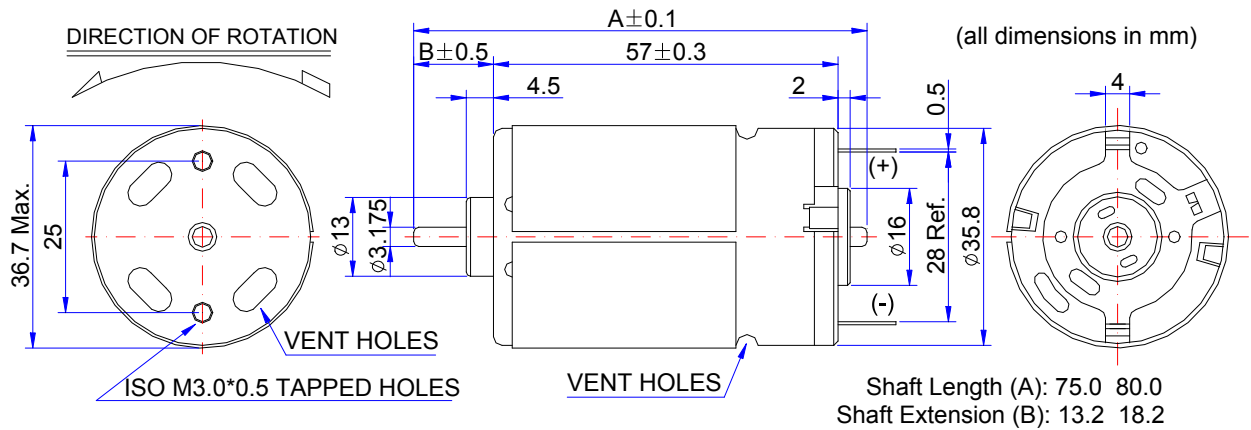

ELECTRICAL SPECIFICATION CHART: (The specifications can be changed as customers' requirement)

Model	Voltage		At No Load		At Max Efficiency					Stall
	Workable Range		Speed	Current	Speed	Current	Torque	Output	Torque	
			RPM	A	RRPM	A	G.CM	W	%	G.CM
TW-550SP-2615	15~30V	24.0V Constant	7300	0.15	6400	1.06	274	17.90	70.5	2220
TW-550SP-5045	6~18V	12.0V Constant	12200	0.65	10770	4.90	371	41.00	70.0	3170
TW-550SP-6530	3~12V	6.0V Constant	9200	0.90	8000	6.00	320	26.20	72.0	2450
TW-550SP-6530	3~12V	7.2V Constant	10900	1.10	9450	7.17	376	36.40	70.0	2840
TW-550SP-7522	3~9V	4.8V Constant	10200	1.30	8920	9.00	347	31.76	73.0	2770
TW-550SP-7522	3~9V	7.2V Constant	15300	1.60	13350	10.90	433	59.00	75.0	3400

CHARACTERISTIC CURVES:

